



Pressure transmitter

HDA 4400

Hydrogen, Ex applications

CSA Approval

Intrinsically safe, Non incendive

Relative pressure

Accuracy 0.5 %



Features

- Specially designed for the measurement of hydrogen
- Parts in contact with the fluid: 1.4435 with a Ni content $\geq 13\%$ (316L)
- ^cCSA_{US} Approval for Canada and USA
- Ignition protection type: Intrinsically safe, Non-incendive

Description

The pressure transmitter series HDA 4400 has been specially developed for measuring tasks with hydrogen. The transmitters are based on a robust, long-life sensor cell with a thin-film strain gauge on a stainless steel membrane. The sensor cell is welded to the process connection, there are no internal seals. The compatibility with hydrogen is ensured by using a particular material. All hydrogen-wetted parts are made of stainless steel 1.4435 with a Ni content of $\geq 13\%$.

The pressure transmitters are applicable in potentially explosive atmospheres, and for this purpose, they are available as ignition protection types "intrinsically safe" and "non-incendive" approved for the use on the North American market.

Application fields

The applications can be found throughout the hydrogen cycle, beginning with systems for hydrogen production (i.e. electrolyzers) through to systems for hydrogen fueling stations, but also in test stands for hydrogen system components etc.

Intrinsically safe

Class I	Division 1	Group A, B, C, D	T6	[C, US]
Class II	Division 1	Group E, F, G		[C, US]
Class III				[C, US]
Class I	Zone 0	AEx ia IIC	T6 Ga	[US]
		Ex ia IIC	T6 Ga	[C]
	Zone 20	AEx ia IIIC	T85 °C Da	[US]
		Ex ia IIIC	T85 °C Da	[C]

Non incendive

Class I	Division 2	Group A, B, C, D, T6, T5, T4		[C, US]
Class II	Division 2	Group F, G		[C, US]
Class III				[C, US]
Class I	Zone 2	AEx ic IIC	T6, T5, T4 Gc	[US]
		Ex ic IIC	T6, T5, T4 Gc	[C]
	Zone 2	AEx nA IIC	T6, T5, T4 Gc	[US]
		Ex nA IIC	T6, T5, T4 Gc	[C]
	Zone 22	AEx tc IIIB	T80 °C, T90 °C, T100 °C Dc	[US]
		Ex tc IIIB	T80 °C, T90 °C, T100 °C Dc	[C]

Technical data

Input data												
Measuring ranges ¹⁾	bar	16	25	40	60	100	200	250	400	500	600	1050
Overload pressures	bar	50	50	80	120	200	500	500	800	1000	1000	1400
Burst pressure	bar	125	125	200	300	500	1250	1250	2000	3000	3000	3000
Mechanical connection (Tightening torque, recommended)	SF250CX20, Autoclave (7/16-20 UNF 2B) (15 Nm for measuring range ≤ 600 bar; 20 Nm for measuring range 1050 bar) G 1/4 B DIN EN 837 (20 Nm for measuring range ≤ 600 bar; 40 Nm for measuring range 1050 bar)											
Parts in contact with the fluid	Stainless steel	1.4435 (Ni content ≥ 13 %)										
	Measurement cell	Additionally gold-plated										
	Seal	Copper (Cu-DHP) (G 1/4 B)										
Output data												
Output signal, permitted load resistance	4 .. 20 mA, 2-conductor, $R_{Lmax} (U_B - 12 V) / 20 mA [k\Omega]$											
Accuracy acc. to DIN 16086, terminal based	≤ ± 0.5 % FS typ. ≤ ± 1 % FS max.											
Accuracy, B.F.S.L	≤ ± 0.25 % FS typ. ≤ ± 0.5 % FS max.											
Temperature compensation zero point	≤ ± 0.015 % FS / °C typ. ≤ ± 0.025 % FS / °C max.											
Temperature compensation span	≤ ± 0.015 % FS / °C typ. ≤ ± 0.025 % FS / °C max.											
Non-linearity acc. to DIN 16086, terminal based	≤ ± 0.3 % FS max.											
Hysteresis	≤ ± 0.4 % FS max.											
Repeatability	≤ ± 0.1 % FS											
Rise time	≤ 2 ms											
Long-term drift	≤ ± 0.3 % FS typ. / year											
Environmental conditions												
Compensated temperature range	-25 .. +85 °C											
Operation / ambient / fluid temperature range ²⁾	T6, T80/T85 °C	Ta = -40 .. +60 °C										
	T5, T90 °C	Ta = -40 .. +70 °C										
	T100 °C	Ta = -40 .. +80 °C										
	T4	Ta = -40 .. +85 °C										
Storage temperature range	-40 .. +100 °C											
Vibration resistance acc. to DIN EN 60068-2-6 at 10 .. 500 Hz	≤ 10 g (1/2-14 NPT Conduit) ≤ 20 g (male connector)											
Shock resistance acc. to DIN EN 60068-2-27	≤ 50 g / 6 ms (1/2-14 NPT Conduit) ≤ 100 g / 6 ms (male connector)											
Protection type acc. to ³⁾	DIN EN 60529 ISO 20653	IP 67 (male connector) IP6K9K (1/2-14 NPT Conduit)										
Relevant data for Ex applications					Ex ia			Ex ic			Ex nA, Ex tc	
Supply voltage	12 .. 28 V DC				12 .. 28 V DC			12 .. 28 V DC			12 .. 28 V DC	
Max. input current	Ii = 100 mA											
Maximum input power	Pi = 1 W											
Connection capacitance of the sensor	Ci ≤ 22 nF				Ci ≤ 22 nF							
Inductance of the sensor	Li = 0 mH				Li = 0 mH							
Insulation voltage	50 V AC, with integrated overvoltage protection											
Other data												
Residual ripple of supply voltage	≤ 5 %											
Current consumption	≤ 25 mA											
Life expectancy	> 10 million load cycles (0 .. 100 % FS)											
Weight	~ 150 g; ~ 300 g (1/2-14 NPT Conduit)											

Note: Reverse polarity protection of the supply voltage, overvoltage, override and short circuit protection are provided.

FS (Full Scale) = relative to complete measuring range

B.F.S.L. = Best Fit Straight Line

¹⁾ psi measuring ranges on request

²⁾ With electrical connection M12x1 and EN 175301-803, max. Ta = +70 °C

³⁾ With mounted mating connector in corresponding protection type

Dimensions

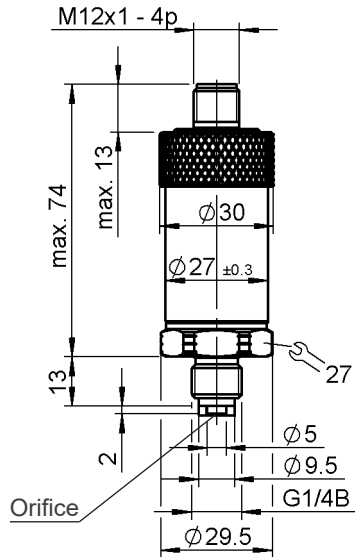

Electrical Connection Variants

Male connector EN175301-803, 3 pole + PE

Related mating connector ZBE01 included in delivery

Mechanical Connection Variants

SF250CX20 Autoclave (7/16-20 UNF 2B female thread)

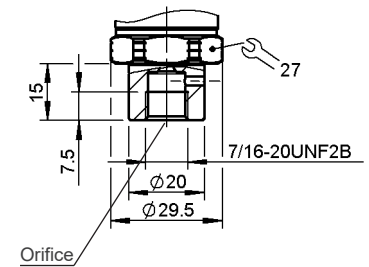
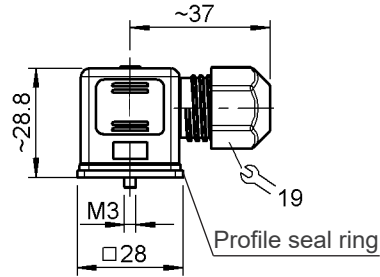
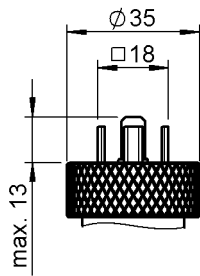

Pin connections

M12x1, 4 pole

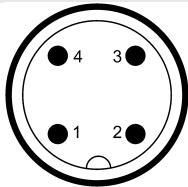

Pin Output signal: A

1	Signal +
2	n.c.
3	Signal -
4	n.c.

EN 175301-803, 3 pole+PE

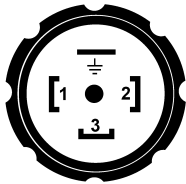

Pin Output signal: A

1	Signal +
2	Signal -
3	n.c.
⊥	Housing

9 = 1/2-14 NPT conduit, single leads

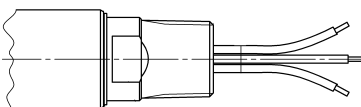

Lead

Output signal: A

Green	Signal +
White	Signal -
Green-yellow	Housing

Model code

HDA 4 4 X X - A - XXXX - C N X - H00 (2m)

Mechanical connection

C = SF250CX20, Autoclave (7/16-20 UNF 2B)
G = G1/4 B DIN EN 837

Electrical connection

5 = Male connector EN 175301-803, 3 pole + PE (IP 67 mating connector included)
6 = Male connector M12X1, 4 pole (mating connector not included)
9 = 1/2-14 NPT conduit connector, single leads

Output signal

A = 4 .. 20 mA, 2 connector

Measuring ranges in bar

0016; 0025; 0040; 0060; 0100; 0200; 0250; 0400; 0500; 0600; 1050

Approval

C = CSA

Insulation voltage

N = 50 V AC to housing

Protection types and application fields (code)

(see following table)

Modification number

H00 = for hydrogen applications

Cable length (for Conduit connection only, not applicable for device connectors)

Standard = 2 m

Code no. Model code	CSA certificate number 1760344	Protection types and application fields	Electrical connection (see model code)
A =	Class I Division 1 Group A, B, C, D T6 Class II Division 1 Group E, F, G Class III Class I Zone 0 AEx ia IIC T6 Ga Ex ia IIC T6 Ga Zone 20 AEx ia IIIC T85 °C Da Ex ia IIIC T85 °C Da	Intrinsically Safe Gases and Dusts	9
B =	Class I Division 1 Group A, B, C, D T6 Class I Zone 0 AEx ia IIC T6 Ga Ex ia IIC T6 Ga Class I Division 2 Group A, B, C, D, T6, T5, T4 Class I Zone 2 AEx ic IIC T6, T5, T4 Gc Ex ic IIC T6, T5, T4 Gc	Intrinsically Safe Gases Non incendive with field wiring Gases	5;6;9
C =	Class I Division 2 Group A, B, C, D, T6, T5, T4 Class II Division 2 Group F, G Class III Class I Zone 2 AEx nA IIC T6, T5, T4 Gc Ex nA IIC T6, T5, T4 Gc Zone 22 AEx tc IIIB T80 °C, T90 °C, T100 °C Dc Ex tc IIIB T80 °C, T90 °C, T100 °C Dc	Non incendive Gases and dusts	9

Note:

Devices for other protection types and application fields are available on request.

Note

The information in this brochure relates to the operating conditions and applications described.

For applications or operating conditions not described, please contact the relevant technical department.

Subject to technical modifications.

HYDAC ELECTRONIC GMBH

Hauptstraße 27
66128 Saarbrücken/Germany
Telephone +49 (0)6897 509-01
Fax +49 (0)6897 509-1726
E-mail: electronic@hydac.com
Internet: www.hydac.com